

## Dynamic Modelling of the three-phase Induction Motor using SIMULINK-MATLAB

Sanjay J. Patel<sup>1</sup>, Jasmin M. Patel<sup>2</sup>, Hitesh B. Jani<sup>3</sup>

<sup>1</sup>Electrical Engineering Department, A.V.P.T.I- Rajkot

<sup>2</sup>Electrical Engineering Department, Government Polytechnic

<sup>3</sup>Electrical Engineering Department, Government Polytechnic

**Abstract — In this paper, a modular Simulink model implementation of an induction motor model is described in a step-by-step approach. The model is based on two-axis theory of revolving transformation. With the modular system, each block solves one of the model equations; therefore unlike black box models, all of the machine parameters are accessible for control and verification purposes. After the implementation, examples are given with the model used in different drive applications. The model takes power source and load torque as input and gives speed and electromagnetic torque as output.**

**Keywords: SIMULINK, MATLAB**

### I. INTRODUCTION

The induction motor per-phase equivalent circuit discussed thus far is only valid for steady-state operation. The dynamic model of the machine is important for transient analysis. When the machine is placed in a feedback control loop for controlling its speed, the dynamics of the machine model dictate the stability of the system. The machine's dynamics are complex because the rotor windings move with respect to stator windings, creating a transformer with time-changing coupling coefficient.

### II. AXES TRANSFORMATION

Consider a symmetrical three-phase induction machine with stationary as-bs-cs axes at  $2\pi/3$ -angle apart, as shown in Figure 1. Our goal is to transform the three-phase stationary reference frame (as-bs-cs) variables in to two-phase stationary reference frame ( $d^s - q^s$ ) variables and then transform these to synchronously rotating reference frame ( $d^e - q^e$ ), and vice versa.

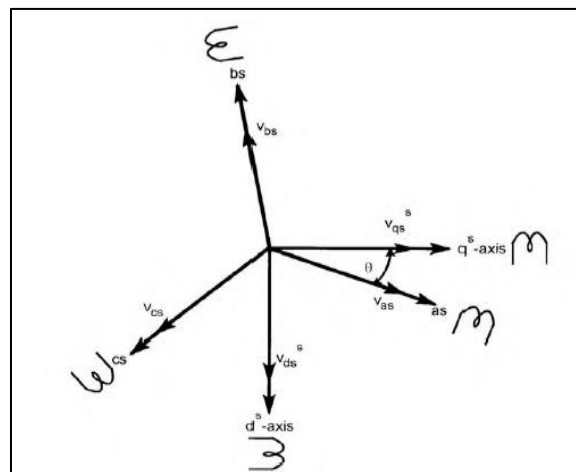

**Figure 1. Stationary frame (as-bs-cs to  $d^s - q^s$ ) axes transformation**

Since a three-phase machine is equivalent to a two-phase machine, the variables of a three-phase machine can be converted into those of a two-phase machine, and vice versa. Consider a symmetrical three-phase machine with the  $as$  axis aligned at lagging angle  $\theta$  with respect to the horizontal line. The equivalent two-phase machine stator axes  $d^s$  and  $q^s$  (also defined as  $\alpha, \beta$  axes) at  $90^\circ$  phase difference are shown in the figure, where the  $q^s$  axis is aligned horizontally with the  $d^s$  axis lagging. If three phase voltages  $v_{as}, v_{bs},$  and  $v_{cs}$  are applied in the respective stator phases, the corresponding two-phase machine stator phase voltages  $v_{ds}^s$  and  $v_{qs}^s$  in Cartesian form can be derived by resolving the three phase voltages into the respective axes components. For convenience, it can be assumed that the  $q^s$  and  $as$  axes are aligned ( $\theta = 0$ ). In that case, the  $v_{as}, v_{bs},$  and  $v_{cs}$  voltages can be expressed in terms of  $v_{ds}^s$  and  $v_{qs}^s$  voltages, as given in Eqs. (1)–(3). From these equations,  $v_{ds}^s$  and  $v_{qs}^s$  expressions can be solved in terms of  $v_{as}, v_{bs},$  and  $v_{cs}$  as shown in Eqs.(4) and (5). The  $q$  and  $d$  axis components can be combined into the complex polar form shown in Eq.(6), where  $a = e^{j2\pi/3}$ . Similar expressions are also valid in three-phase ( $ar, br, cr$ ) to two-phase ( $dr^r, qr^r$ ) rotor phase voltages transformations, and vice versa.

Assume that the  $d^s - q^s$  axes are oriented at  $\theta$  angle, as shown in fig.2. The voltage  $v_{ds}^s$  and  $v_{qs}^s$  can be resolved in to as  $as - bs - cs$  components and can be represented in the matrix form as

$$\begin{bmatrix} v_{as} \\ v_{bs} \\ v_{cs} \end{bmatrix} = \begin{pmatrix} \cos \theta & \sin \theta & 1 \\ \cos(\theta - 120^\circ) & \sin(\theta - 120^\circ) & 1 \\ \cos(\theta + 120^\circ) & \sin(\theta + 120^\circ) & 1 \end{pmatrix} \begin{bmatrix} v_{qs}^s \\ v_{ds}^s \\ v_{os}^s \end{bmatrix} \quad (1)$$

The corresponding inverse relation is

$$\begin{bmatrix} v_{qs}^s \\ v_{ds}^s \\ v_{as}^s \end{bmatrix} = \frac{2}{3} \begin{pmatrix} \cos \theta & \cos(\theta - 120^\circ) & \cos(\theta + 120^\circ) \\ \sin \theta & \sin(\theta - 120^\circ) & \sin(\theta + 120^\circ) \\ 0.5 & 0.5 & 0.5 \end{pmatrix} \begin{bmatrix} v_{as} \\ v_{bs} \\ v_{cs} \end{bmatrix} \quad (2)$$

Where,  $v_{os}^s$  is added as the sequence component, which may or may not be present. We have considered voltage as the variable. The current and flux linkages can be transformed by similar equations.

It is convenient to set  $\theta = 0$ , so that the  $q^s$ -axis is aligned with the  $as -$  axis. Ignoring the zero sequence components, the transformation relation can be simplified as

$$V_{as} = V_{qs}^s \quad (3) \quad V_{bs} = -\frac{1}{2}V_{qs}^s - \frac{\sqrt{3}}{2}V_{ds}^s \quad (4) \quad V_{cs} = -\frac{1}{2}V_{qs}^s + \frac{\sqrt{3}}{2}V_{ds}^s \quad (5)$$

$$V_{qs}^s = \frac{2}{3}V_{as} - \frac{1}{3}V_{bs} - \frac{1}{3}V_{cs} = V_{as} \quad (6) \quad V_{ds}^s = -\frac{1}{\sqrt{3}}V_{bs} + \frac{1}{\sqrt{3}}V_{cs} \quad (7)$$

Fig 2 shows the synchronously rotating  $d^e - q^e$  axes, which rotate at synchronous speed  $w_e$  with respect to the  $d^s - q^s$  axes and the angle  $\theta_e = \omega_e t$ . The two-phase  $d^s - q^s$  windings are transformed

into the hypothetical windings mounted on the  $d^e-q^e$  axes. The voltages on the  $d^s-q^s$  axes can be converted in to  $d^e-q^e$  frame as follows:

hypothetical windings mounted on the  $d^e-q^e$  axes. The voltages on the  $d^s-q^s$  axes can be converted in to  $d^e-q^e$  frame as follows:

$$V_{ds} = V_{qs}^s \sin \theta_e + V_{ds}^s \cos \theta_e \tag{8}$$

$$V_{qs} = V_{qs}^s \cos \theta_e - V_{ds}^s \sin \theta_e \tag{9}$$

$$V_{ds} = -V_{qs}^s \sin \theta_e + V_{ds}^s \cos \theta_e \tag{10}$$

$$V_{qs}^s = V_{qd} \cos \theta_e + V_{ds} \sin \theta_e \tag{11}$$

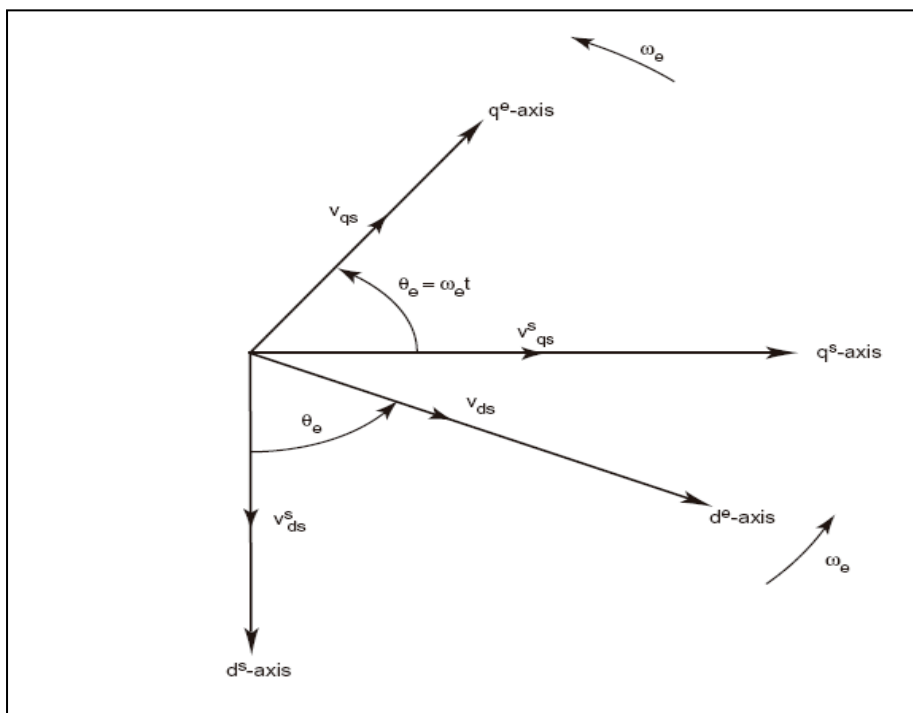

**Figure 2. Stationary frame to synchronously rotating frame transformation.**

### III. SYNCHRONOUSLY ROTATING REFERENCE FRAME- DYNAMIC MODEL

For the two-phase machine shown in Figure 1, we need to represent both  $d^s - q^s$  and  $d^r - q^r$  circuits and their variable in a synchronously rotating  $d^e - q^e$  frame. We can write the following stator circuits equations:

$$v_{qs}^s = R_s i_{qs}^s + \frac{d}{dt} \psi_{qs}^s \tag{12}$$

$$v_{ds}^s = R_s i_{ds}^s + \frac{d}{dt} \psi_{ds}^s \tag{13}$$

When these equations are converted to  $d^e - q^e$  frame, the following equations can be written:

$$v_{qs} = R_s i_{qs} + \frac{d}{dt} \psi_{qs} + \omega_e \psi_{ds} \quad (14)$$

$$v_{ds} = R_s i_{ds} + \frac{d}{dt} \psi_{ds} - \omega_e \psi_{qs} \quad (15)$$

Where, all the variables are in rotating form. The last term in Equations (2.14) and (2.15) can be defines as speed emf due to rotating of the axes, that is, when  $\omega = 0$ , the equations revert to stationary form. Note that the flux linkage in the  $d^e$  and  $q^e$  axes, respectively, with  $\pi / 2$  lead angle.

If the rotor is not moving, that is  $\omega_r = 0$ , the rotor equations for a doubly-fed wound-rotor machine will be similar to Equations (14)-(15).

$$v_{qr} = R_r i_{qr} + \frac{d}{dt} \psi_{dr} + \omega_e \psi_{dr} \quad (16)$$

$$v_{dr} = R_r i_{dr} + \frac{d}{dt} \psi_{dr} - \omega_e \psi_{qr} \quad (17)$$

Where all the variables and parameters are referred to the stator, since the rotor actually moves at speed  $\omega_r$ , the  $d - q$  axes fixed on the rotor move at a speed  $\omega_e - \omega_r$  relative to the synchronously rotating frame. Therefore, in  $d^e - q^e$  frame, the rotor equations should be modified as

$$v_{qr} = R_r i_{qr} + \frac{d}{dt} \psi_{qr} + (\omega_e - \omega_r) \psi_{dr} \quad (18)$$

$$v_{dr} = R_r i_{dr} + \frac{d}{dt} \psi_{dr} - (\omega_e - \omega_r) \psi_{qr} \quad (19)$$

Figure 2.4 shows the  $d^e - q^e$  dynamic model equivalent circuits that satisfy Equations (14) and (18)-(19). A special advantage of the  $d^e - q^e$  dynamic model of the machine is that all the sinusoidal variables in stationary frame appear as dc quantities in synchronous frame.

The flux linkage expressions in terms of the currents can be written from Figure 3 as follows

$$\psi_{qs} = L_{ls} i_{qs} + L_m (i_{qs} + i_{qr}) \quad (20)$$

$$\psi_{qr} = L_{lr} i_{qr} + L_m (i_{qs} + i_{qr}) \quad (21)$$

$$\psi_{qm} = L_m (i_{qs} + i_{qr}) \quad (22)$$

$$\psi_{ds} = L_{ls} i_{ds} + L_m (i_{ds} + i_{dr}) \quad (23)$$

$$\psi_{dr} = L_{lr} i_{dr} + L_m (i_{ds} + i_{dr}) \quad (24)$$

$$\psi_{dm} = L_m (i_{ds} + i_{dr}) \quad (25)$$

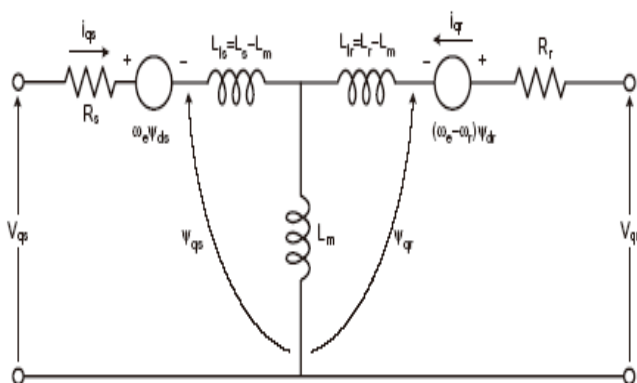

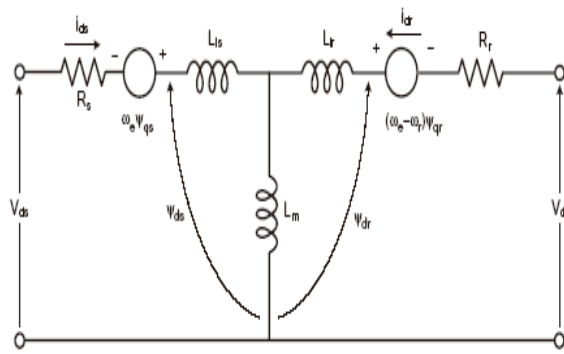

(a)  $q^e$  Axes

(b)  $d^e$  Axes

Figure 3. Dynamic  $d^e - q^e$  equivalent circuit of machine.

Combining the above expressions with Equations (14), (15), (18) and (19), the electrical transient model in term of voltages and currents can be given in matrix form as

$$\begin{bmatrix} v_{qs} \\ v_{ds} \\ v_{qr} \\ v_{dr} \end{bmatrix} = \begin{bmatrix} R_s + sL_s & \omega_e L_s & sL_m & \omega_e L_m \\ -\omega_e L_s & R_s + sL_s & -\omega_e L_m & sL_m \\ sL_m & (\omega_e - \omega_r)L_m & R_r + sL_r & (\omega_e - \omega_r)L_r \\ -(\omega_e - \omega_r)L_m & sL_m & -(\omega_e - \omega_r)L_r & R_r + sL_r \end{bmatrix} \begin{bmatrix} i_{qs} \\ i_{ds} \\ i_{qr} \\ i_{dr} \end{bmatrix} \quad (26)$$

Where,  $s$  is the Laplace operator. For a singly-fed machine, such as a cage motor,  $v_{qr} = v_{dr} = 0$ . If the speed  $\omega_r$  is considered constant (infinite inertia load), the electrical dynamics of the machine are given by a fourth-order linear system. Then, knowing inputs  $v_{qs}, v_{ds}$  and  $\omega_e$  the currents  $i_{qs}, i_{ds}, i_{qr}$  and  $i_{dr}$  can be solved from Equation (26). If the machine is fed by current source,  $i_{qs}, i_{ds}$ , and  $\omega_e$  are independent. Then, the dependent variables  $v_{qs}, v_{ds}, i_{qr}$  and  $i_{dr}$  can be solved from Equation (26)

The speed  $\omega_r$  in Equation (26) cannot normally be treated as a constant. It can be related to the torques as

$$T_e = T_L + J \frac{d\omega_m}{dt} = T_L J \frac{d\omega_r}{dt} \quad (27)$$

Where  $T_L$  = load torque,  $J$  = rotor inertia and  $\omega_m$  = mechanical speed.

Often, for compact representation, the machine model and equivalent circuit are expressed in complex form. Multiplying Equation (15) by  $-j$  and adding with Equation (14) gives

$$v_{qs} - jv_{ds} = R_s(i_{qs} - ji_{ds}) + \frac{d}{dt}(\psi_{qs} - j\psi_{ds}) + j\omega_e(\psi_{qs} - j\psi_{ds}) \quad (28)$$

or

$$v_{qds} = R_s i_{qds} + \frac{d}{dt} \psi_{qds} + j\omega_e \psi_{qds} \quad (29)$$

Where  $v_{qds}, i_{qds}$ , etc. are complex vectors (the superscript  $e$  has been omitted), similarly, the rotor Equations (18)-(19) can be combined to represent

$$v_{qdr} = R_r i_{qdr} + \frac{d}{dt} \psi_{qdr} + j(\omega_e - \omega_r) \psi_{qdr} \quad (30)$$

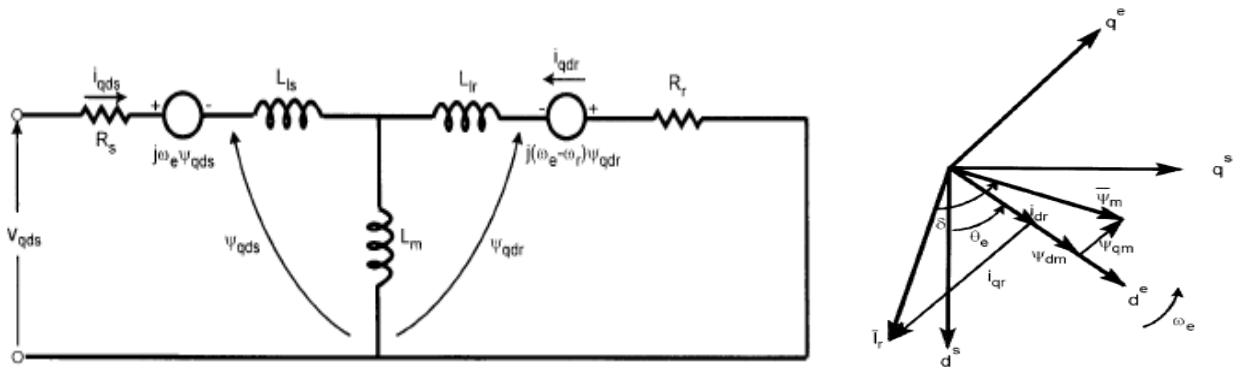

Figure 4. Complex synchronous frame dqS equivalent circuit.

Fig 4 shows the complex equivalent circuit in rotating frame where  $v_{qdr} = 0$ . Note that the steady-state equations can always be derived by substituting the time derivative components to zero. Therefore from Equations (29)-(30), the steady-state equations can be derived as

$$v_s = R_s I_s + j\omega_e \psi_s \quad (31)$$

$$0 = \frac{R_r}{S} I_r + j\omega_e \psi_r \quad (32)$$

Where the complex vectors have been substituted by the corresponding rms phasor. These equations satisfy the steady-state equivalent circuit shown in Figure 4 if the parameter  $R_m$  is neglected.

The development of torque by the interaction of air gap flux and rotor mmf was discussed earlier. Here it will be expressed in more general form, relating the  $d-q$  components of variables. From Equation (1.6), the torque can be generally expressed in the vector forma as

$$T_e = \frac{3}{2} \left( \frac{P}{2} \right) \bar{\psi}_m \times \bar{I}_r \quad (33)$$

Resolving the variables into  $d^e - q^e$  components, as shown in Figure 5.

$$T_e = \frac{3}{2} \left( \frac{P}{2} \right) (\psi_{dm} i_{qr} - \psi_{qm} i_{dr}) \quad (34)$$

Several other torque expressions can be derived easily as follows:

$$T_e = \frac{3}{2} \left( \frac{P}{2} \right) (\psi_{dm} i_{qs} - \psi_{qm} i_{ds}) \quad (35)$$

$$= \frac{3}{2} \left( \frac{P}{2} \right) (\psi_{ds} i_{qs} - \psi_{qs} i_{ds}) \quad (36)$$

$$= \frac{3}{2} \left( \frac{P}{2} \right) L_m (i_{qs} i_{dr} - i_{ds} i_{qr}) \quad (37)$$

$$= \frac{3}{2} \left( \frac{P}{2} \right) (\psi_{dr} i_{qr} - \psi_{qr} i_{dr}) \quad (38)$$

Equation (26), (27), and (37) gives the complete model of the electro-mechanical dynamics of an induction machine in synchronous frame.

#### IV DYNAMIC MODEL STATE-SPACE EQUATIONS

The dynamic machine model in state-space form is important for transient analysis, particularly for computer simulation study. Although the rotating frame model is generally preferred, the stationary frame model can also be used. The electrical variables in the model can be chosen as fluxes, currents, or a mixture of both. In this section, we will derive state-space equations of the machine in rotating frame with flux linkages as the main variables.

Let's define the flux linkage variables as follows:

$$F_{qs} = \omega_b \psi_{qs} \quad (39) \qquad F_{qr} = \omega_b \psi_{qr} \quad (40) \qquad F_{ds} = \omega_b \psi_{ds} \quad (41) \qquad F_{dr} = \omega_b \psi_{dr} \quad (42)$$

Where  $\omega_b$  = base frequency of the machine.

Substituting the above relation in Equations (14)-(15) and (18)-(19), we can write.

$$V_{qs} = R_s i_{qs} + \frac{1}{\omega_b} \frac{dF_{qs}}{dt} + \frac{\omega_e}{\omega_b} F_{ds} \quad (43)$$

$$V_{ds} = R_s i_{ds} + \frac{1}{\omega_b} \frac{dF_{ds}}{dt} + \frac{\omega_e}{\omega_b} F_{qs} \quad (44)$$

$$0 = R_r i_{qr} + \frac{1}{\omega_b} \frac{dF_{qr}}{dt} + \frac{(\omega_e - \omega_r)}{\omega_b} F_{dr} \quad (45)$$

$$0 = R_r i_{dr} + \frac{1}{\omega_b} \frac{dF_{dr}}{dt} + \frac{(\omega_e - \omega_r)}{\omega_b} F_{qr} \quad (46)$$

Where it is assumed that  $v_{qr} = v_{dr} = 0$

Multiplying Equation (20)-(25) by  $\omega_b$  on both sides, the flux linkage expressions can be written as

$$F_{qs} = \omega_b \psi_{qs} = X_{ls} i_{qs} + X_m (i_{qs} + i_{qr}) \quad (47)$$

$$F_{qr} = \omega_b \psi_{qr} = X_{lr} i_{qr} + X_m (i_{qs} + i_{qr}) \quad (48)$$

$$F_{qm} = \omega_b \psi_{qm} = X_m (i_{qs} + i_{qr}) \quad (49)$$

$$F_{ds} = \omega_b \psi_{ds} = X_{ls} i_{ds} + X_m (i_{ds} + i_{dr}) \quad (50)$$

$$F_{dr} = \omega_b \psi_{dr} = X_{lr} i_{dr} + X_m (i_{ds} + i_{dr}) \quad (51)$$

$$F_{dm} = \omega_b \psi_{dm} = X_m (i_{ds} + i_{dr}) \quad (52)$$

where  $X_{ls} = \omega_b L_{ls}$ ,  $X_{lr} = \omega_b L_{lr}$  and  $X_m = \omega_b L_m$ , or

$$F_{qs} = X_{ls} i_{qs} + F_{qm} \quad (53)$$

$$F_{qr} = X_{lr} i_{qr} + F_{qm} \quad (54)$$

$$F_{ds} = X_{ls} i_{ds} + F_{dm} \quad (55)$$

$$F_{dr} = X_{lr} i_{dr} + F_{dm} \quad (56)$$

From Equations (53)-(56), the currents can be expressed in terms of the flux linkages as

$$i_{qs} = \frac{F_{qs} - F_{qm}}{X_{ls}} \quad (57)$$

$$i_{qr} = \frac{F_{qr} - F_{qm}}{X_{lr}} \quad (58)$$

$$i_{ds} = \frac{F_{ds} - F_{dm}}{X_{ls}} \quad (59)$$

$$i_{dr} = \frac{F_{dr} - F_{dm}}{X_{lr}} \quad (60)$$

Substituting equation (58)-(59) in (53)-(54), respectively, the  $F_{qm}$  expression is given as

$$F_{qm} = X_m \left[ \frac{(F_{qs} - F_{qm})}{X_{ls}} + \frac{(F_{qr} - F_{qm})}{X_{lr}} \right] \quad (61)$$

or

$$F_{qm} = \frac{X_{ml}}{X_{ls}} F_{qs} + \frac{X_{ml}}{X_{lr}} F_{qr} \quad (62)$$

where

$$X_{ml} = \frac{1}{\left( \frac{1}{X_m} + \frac{1}{X_{ls}} + \frac{1}{X_{lr}} \right)} \quad (63)$$

Similar derivation can be made for  $F_{dm}$  as follows:

$$F_{dm} = \frac{X_{ml}}{X_{ls}} F_{ds} + \frac{X_{ml}}{X_{lr}} F_{dr} \quad (64)$$

Substituting the current Equations (57)-(60) in to voltage Equations (43)-(46)

$$V_{qs} = \frac{R_s}{X_{ls}} (F_{qs} - F_{qm}) + \frac{1}{\omega_b} \frac{dF_{qs}}{dt} + \frac{\omega_e}{\omega_b} F_{ds} \quad (65)$$

$$V_{ds} = \frac{R_s}{X_{ls}} (F_{ds} - F_{dm}) + \frac{1}{\omega_b} \frac{dF_{ds}}{dt} + \frac{\omega_e}{\omega_b} F_{qs} \quad (66)$$

$$0 = \frac{R_r}{X_{lr}} (F_{qr} - F_{qm}) + \frac{1}{\omega_b} \frac{dF_{qr}}{dt} + \frac{(\omega_e - \omega_r)}{\omega_b} F_{dr} \quad (67)$$

$$0 = \frac{R_r}{X_{lr}} (F_{dr} - F_{dm}) + \frac{1}{\omega_b} \frac{dF_{dr}}{dt} - \frac{(\omega_e - \omega_r)}{\omega_b} F_{qr} \quad (68)$$

which can be expressed in state-space form as

$$\frac{dF_{qs}}{dt} = \omega_b \left[ v_{qs} - \frac{\omega_e}{\omega_b} F_{ds} - \frac{R_s}{X_{ls}} (F_{qs} - F_{qm}) \right] \quad (69)$$

$$\frac{dF_{ds}}{dt} = \omega_b \left[ v_{ds} - \frac{\omega_e}{\omega_b} F_{qs} - \frac{R_s}{X_{ls}} (F_{ds} - F_{dm}) \right] \quad (70)$$

$$\frac{dF_{qr}}{dt} = -\omega_b \left[ \frac{(\omega_e - \omega_r)}{\omega_b} F_{dr} + \frac{R_r}{X_{lr}} (F_{qr} - F_{qm}) \right] \quad (71)$$

$$\frac{dF_{dr}}{dt} = -\omega_b \left[ -\frac{(\omega_e - \omega_r)}{\omega_b} F_{qr} + \frac{R_r}{X_{lr}} (F_{dr} - F_{dm}) \right] \quad (72)$$

Finally form Equation (36),

$$T_e = \frac{3}{2} \left( \frac{P}{2} \right) \frac{1}{\omega_b} (F_{ds} i_{qs} - F_{qs} i_{ds}) \quad (73)$$

Equations (69)-(73), along with Equation (27), describe the complete model in state-space form where  $F_{qs}$ ,  $F_{ds}$ ,  $F_{qr}$ , and  $F_{dr}$  are the state variables.

## V SIMULINK INDUCTION MACHINE MODEL

The inputs of a squirrel cage induction machine are the three-phase voltages, their fundamental frequency, and the load torque. The outputs, on the other hand, are the three phase currents, the electrical torque, and the rotor speed. The d-q model requires that all the three-phase variables have to be transformed to the two-phase synchronously rotating frame. Consequently, the induction machine model will have blocks transforming the three-phase voltages to the d-q frame and the d-q currents back to three-phase. The induction machine model implemented is shown in Fig. 5

It consists of five major blocks:

- The o-n conversion
- abc-syn conversion
- syn-abc conversion
- Unit vector calculation, and
- The induction machine d-q model blocks.

The following subsections will explain each block.

### [A] O-N Conversion Block

This block is required for an isolated neutral system, otherwise it can be bypassed. The transformation done by this block can be represented as follows:

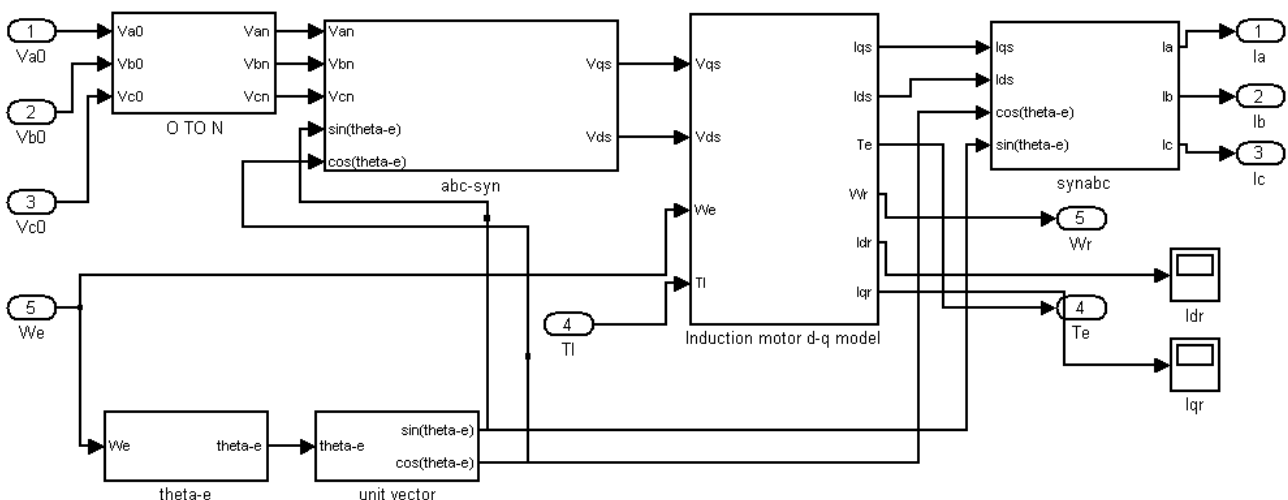

Figure 5. The complete induction machine simulink model

$$\begin{bmatrix} V_{an} \\ V_{bn} \\ V_{cn} \end{bmatrix} = \begin{bmatrix} +\frac{2}{3} & -\frac{1}{3} & -\frac{1}{3} \\ -\frac{1}{3} & +\frac{2}{3} & -\frac{1}{3} \\ -\frac{1}{3} & -\frac{1}{3} & +\frac{2}{3} \end{bmatrix} \begin{bmatrix} V_{ao} \\ V_{bo} \\ V_{co} \end{bmatrix} \quad (74)$$

This is implemented in Simulink by passing the input voltages through a Simulink "Matrix Gain" block, which contains the above transformation matrix.

- **O-N Conversion simulink block sub-system:**

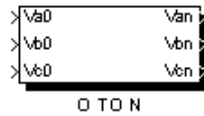

Figure 6. O-N conversion simulink block sub-system.

- **O-N Conversion simulink block :**

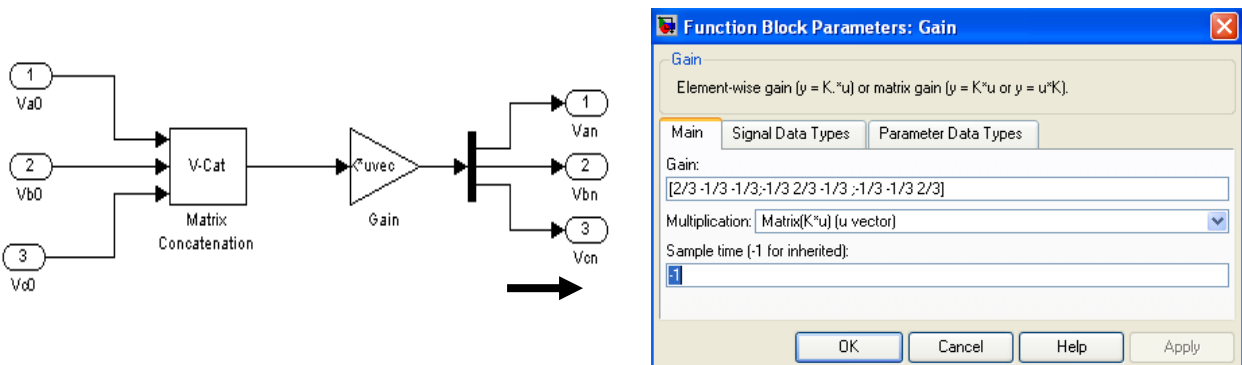

Figure 7. O-N conversion simulink block.

## [B] Unit Vector Block Calculation

Unit vectors  $\cos \theta_e$  and  $\sin \theta_e$  are used in vector rotation blocks, "abc-syn conversion block" and "syn-abc conversion block". The angle  $\theta_e$  is calculated directly by integrating the frequency of the input three-phase voltages,  $\omega_e$ .

$$\theta_e = \int \omega_e dt \quad (75)$$

The unit vectors are obtained simply by taking the sine and cosine of  $\theta_e$ . This block is also where the initial rotor position can be inserted, if needed, by adding an initial condition to the Simulink "Integrator" block.

- $\theta_e$  calculation simulink block:

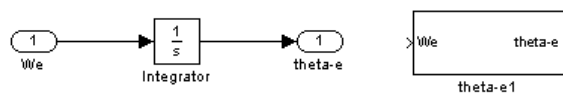

Figure 8.  $\theta_e$  Calculation simulink block.

- $\sin \theta_e$  and  $\cos \theta_e$  [ Unit Vector] calculation simulink block :

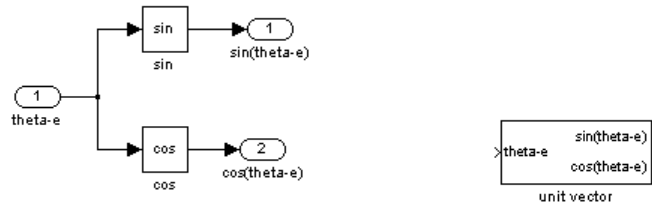

Figure 9. Unit vector simulink block.

[C] abc-syn conversion block

To convert three-phase voltages to voltages in the two-phase synchronously rotating frame, they are first converted to two-phase stationary frame using (76) and then from the stationary frame to the synchronously rotating frame using Eqs. (77)

$$\begin{bmatrix} V_{qs}^s \\ V_{ds}^s \end{bmatrix} = \begin{bmatrix} 1 & 0 & 0 \\ 0 & -\frac{1}{\sqrt{3}} & -\frac{1}{\sqrt{3}} \end{bmatrix} \begin{bmatrix} V_{an} \\ V_{bn} \\ V_{cn} \end{bmatrix} \quad (76)$$

$$\left. \begin{aligned} V_{qs} &= V_{qs}^s \cos \theta_e - V_{ds}^s \sin \theta_e \\ V_{ds} &= V_{qs}^s \sin \theta_e + V_{ds}^s \cos \theta_e \end{aligned} \right\} \quad (77)$$

where the superscript "s" refers to stationary frame.

Equation (76) is implemented similar to (74) because it is a simple matrix transformation. Equation (77), however, contains the unit vectors; therefore, a simple matrix transformation cannot be used. Instead, vqs and vds are calculated using basic Simulink "Sum" and "Product" blocks.

- abc-syn conversion simulink block and simulink block sub-system & abc-syn-2 conversion simulink block sub-system

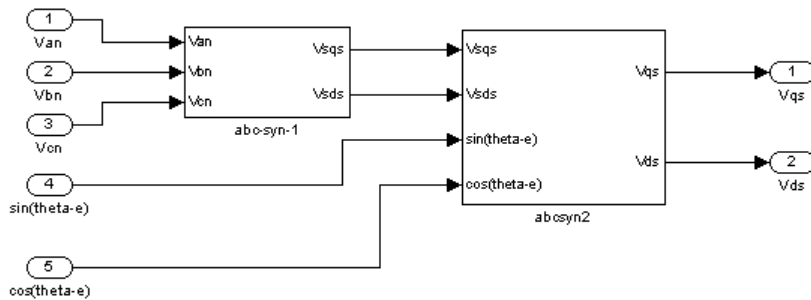

Figure 10. abc-syn conversion simulink block.

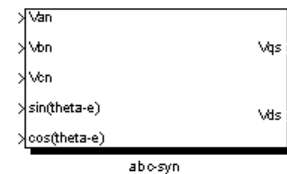

Figure 11. abc-syn conversion simulink block sub-system.

- abc-syn conversion simulink block

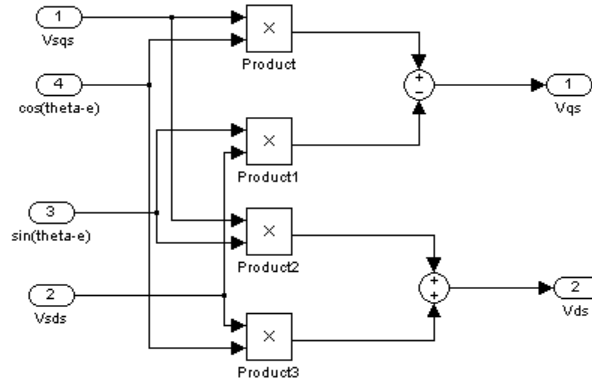

Figure 12. abc-syn-2 conversion simulink block.

- abc-syn-1 conversion simulink block :

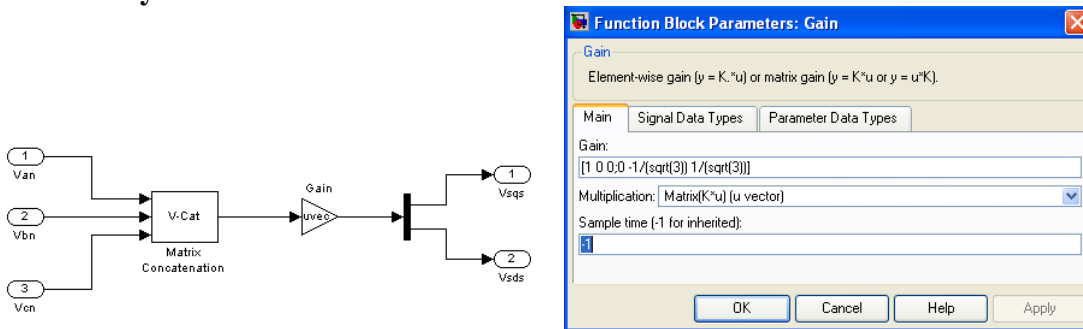

Figure13. abc-syn-1 conversion simulink block.

**[D] syn-abc conversion block**

This block does the opposite of the abc-syn conversion block for the current variables using (78) and (79) following the same implementation techniques as before.

$$\left. \begin{aligned} i_{qs} &= V_{qs} \cos \theta_e + V_{ds} \sin \theta_e \\ i_{ds} &= -V_{qs} \sin \theta_e + V_{ds} \cos \theta_e \end{aligned} \right\} \quad (78)$$

$$\begin{bmatrix} i_a \\ i_b \\ i_c \end{bmatrix} = \begin{bmatrix} +1 & 0 \\ -\frac{1}{2} & -\frac{\sqrt{3}}{2} \\ -\frac{1}{2} & +\frac{\sqrt{3}}{2} \end{bmatrix} \begin{bmatrix} i_{qs}^s \\ i_{ds}^s \end{bmatrix} \quad (79)$$

- syn-abc conversion simulink block & syn-abc conversion simulink block sub-system

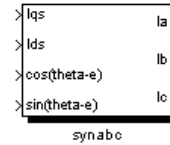
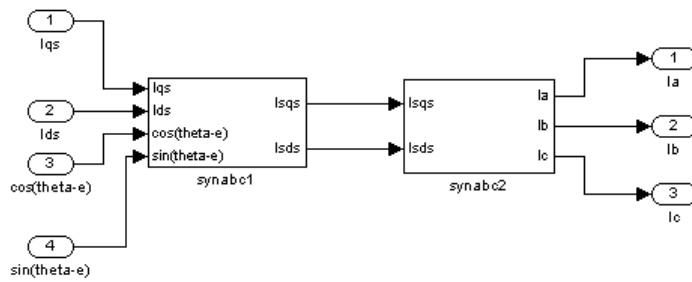

Figure 14. Syn-abc conversion simulink block

Figure 15. Syn-abc conversion sub-system simulink block.

- **syn-abc-1 conversion simulink block**

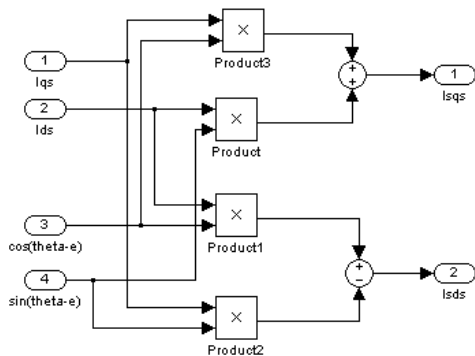

Figure 16. syn-abc-1 conversion simulink block.

- **syn-abc-2 conversion simulink block sub-system**

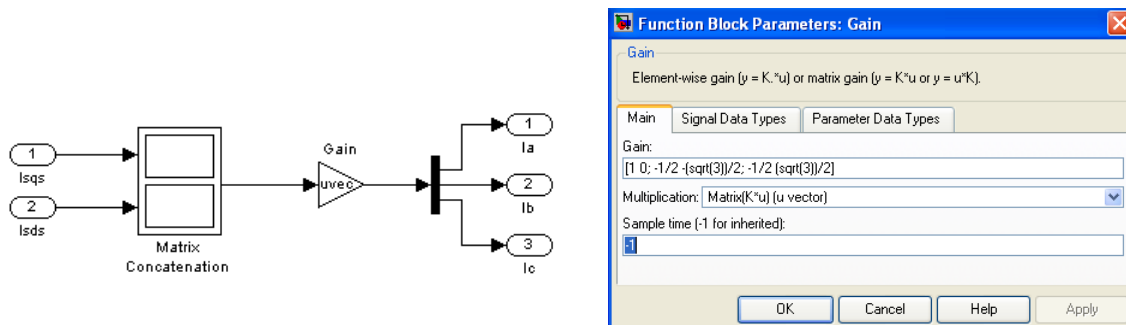

Figure 17. syn-abc-2 conversion simulink block.

**[E]. Induction machine d-q model block**

Fig.18 shows the inside of this block where each equation from the induction machine model is implemented in a different block. First consider the flux linkage state equations because flux linkages are required to calculate all the other variables. These equations could be implemented using Simulink

"State-space" block, but to have access to each point of the model, implementation using discrete blocks is preferred.

The resulting model is modular and easy to follow. Any variable can be easily traced using the Simulink 'Scope' blocks. The blocks in the first two columns calculate the flux linkages, which can be used in vector control systems in a flux loop. The blocks in Columns 3 calculate all the current variables, which can be used in the current loops of any current control system and to calculate the three-phase currents. The two blocks of Column 4, on the other hand, calculate the torque and the speed of the induction machine, which again can be used in torque control or speed control loops. These two variables can also be used to calculate the output power of the machine.

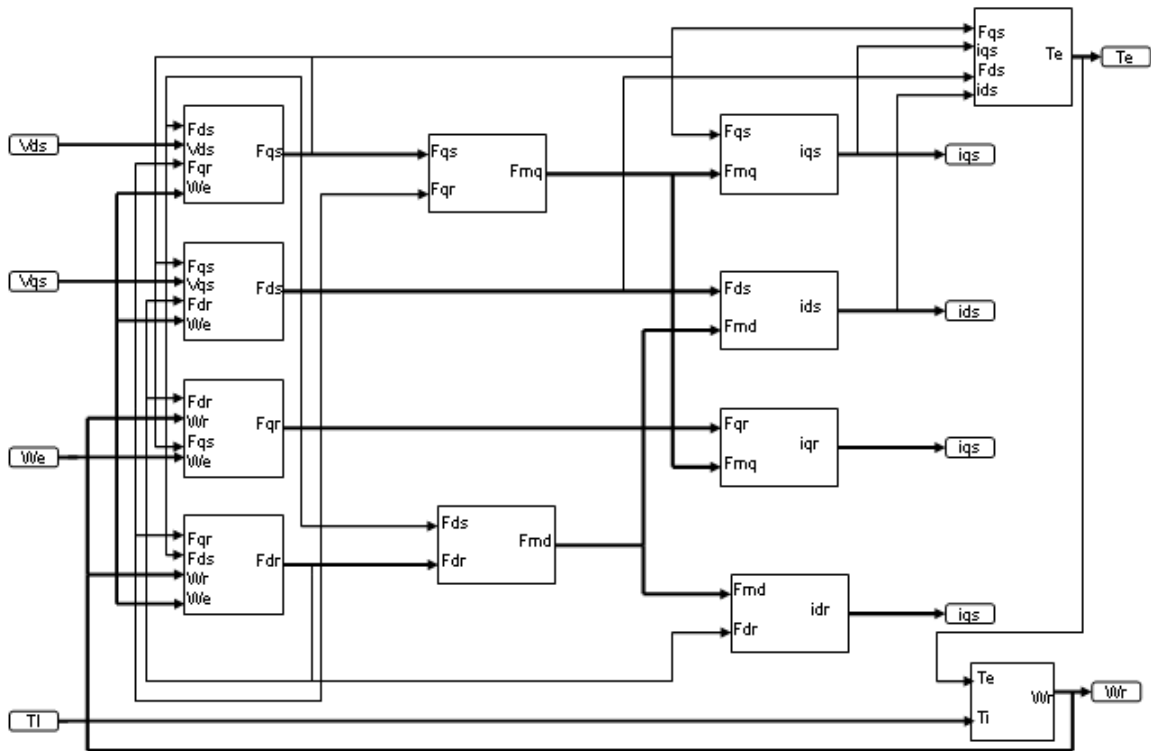

Figure 18. Induction machine d-q model block.

- Fdr Matlab simulink block sub-system & Fdr Matlab simulink block sub-system

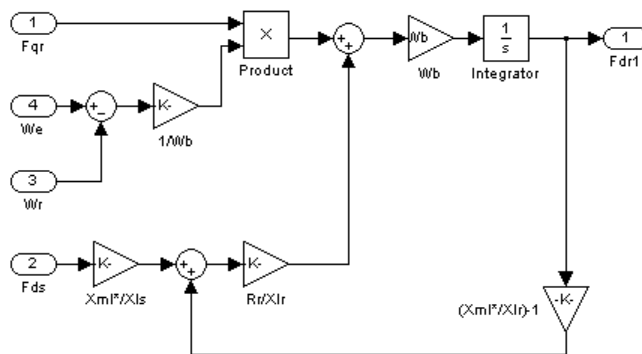

Figure 19. Fdr simulink block sub-system.

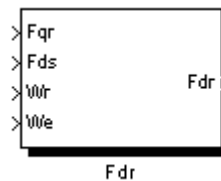

Figure 20. Fdr matlab simulink block sub-system.

• **Fds Matlab simulink block & Fds Matlab simulink block Sub-system**

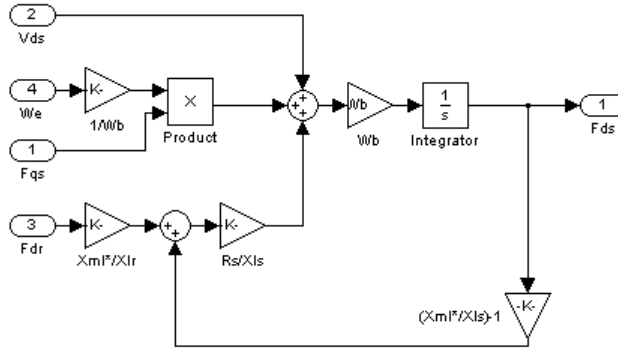

Figure 21. Fds matlab simulink block

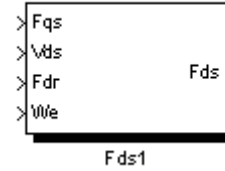

Figure 22. Fds matlab simulink block sub-system.

• **Fqr Matlab simulink block sub-system & Fqr Matlab simulink block**

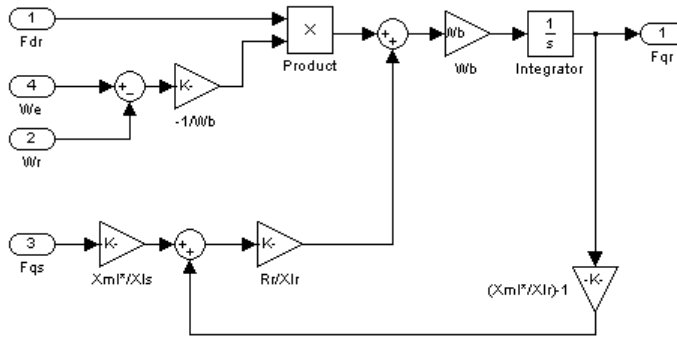

Figure 23. Fqr matlab simulink block.

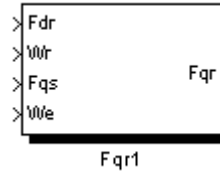

Figure 24. Fqr matlab simulink block sub-system.

• **Fqs Matlab simulink block Sub-system & Fqs Matlab simulink block**

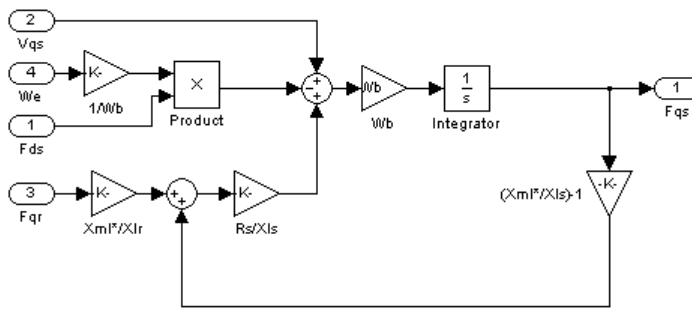

Figure 25. Fqs matlab simulink block sub-system

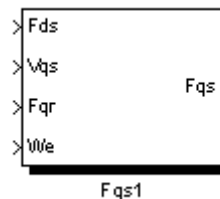

Figure 26. Fqs matlab simulink block.

• **Fmd Matlab simulink block & Fmd Matlab simulink block sub-system**

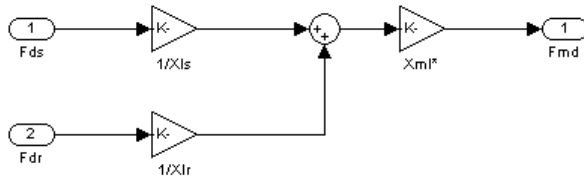

Figure 27. Fmd matlab simulink block.

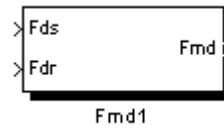

Figure 28. Fmd matlab simulink block sub-system.

- Fmq Matlab simulink block & Fmq Matlab simulink block sub-system

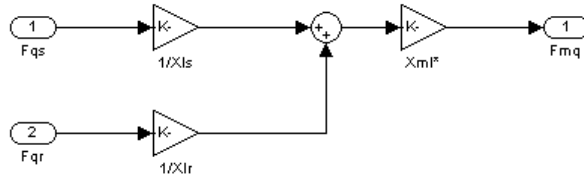

Figure 29. Fmq matlab simulink block.

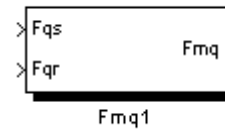

Figure 30. Fmq matlab simulink block sub-system.

- Iqr Matlab simulink block & Iqr Matlab simulink block sub-system

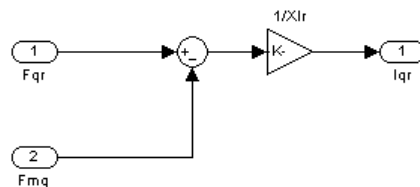

Figure 31. Iqr matlab simulink block.

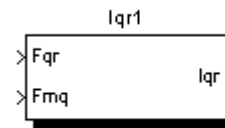

Figure 32. Iqr matlab simulink block sub-system.

- Iqs Matlab simulink block & Iqs Matlab simulink block sub-system

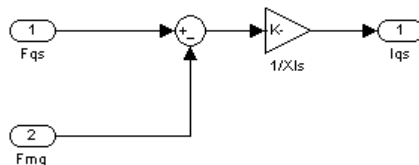

Figure 33. Iqs matlab simulink block.

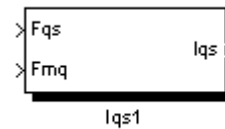

Figure 34. Iqs matlab simulink block sub-system.

- Idr Matlab simulink block & Idr Matlab simulink block sub-system

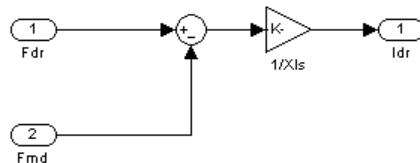

Figure 35. Idr matlab simulink block.  
 block sub-system.

Figure 36. Idr matlab simulink  
 block sub-system.

- Ids Matlab simulink block & Ids Matlab simulink block sub-system

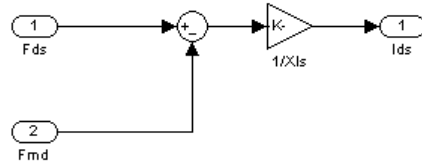

Figure 37. Ids matlab simulink block.  
 block sub-system.

Figure 38. Ids matlab simulink  
 block sub-system.

- Te Matlab simulink block & Te Matlab simulink block sub-system

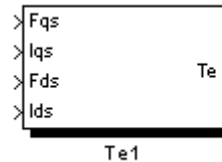
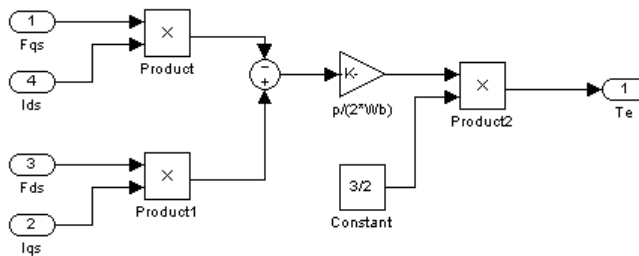

Figure 39. Te matlab simulink block.  
 block sub-system.

Figure 40. Te matlab simulink  
 block sub-system.

- $\omega_r$  Matlab simulink block &  $\omega_r$  Matlab simulink block sub-system

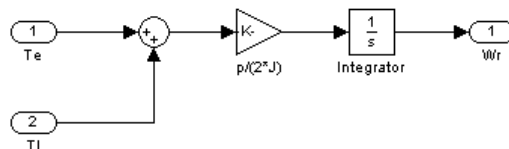
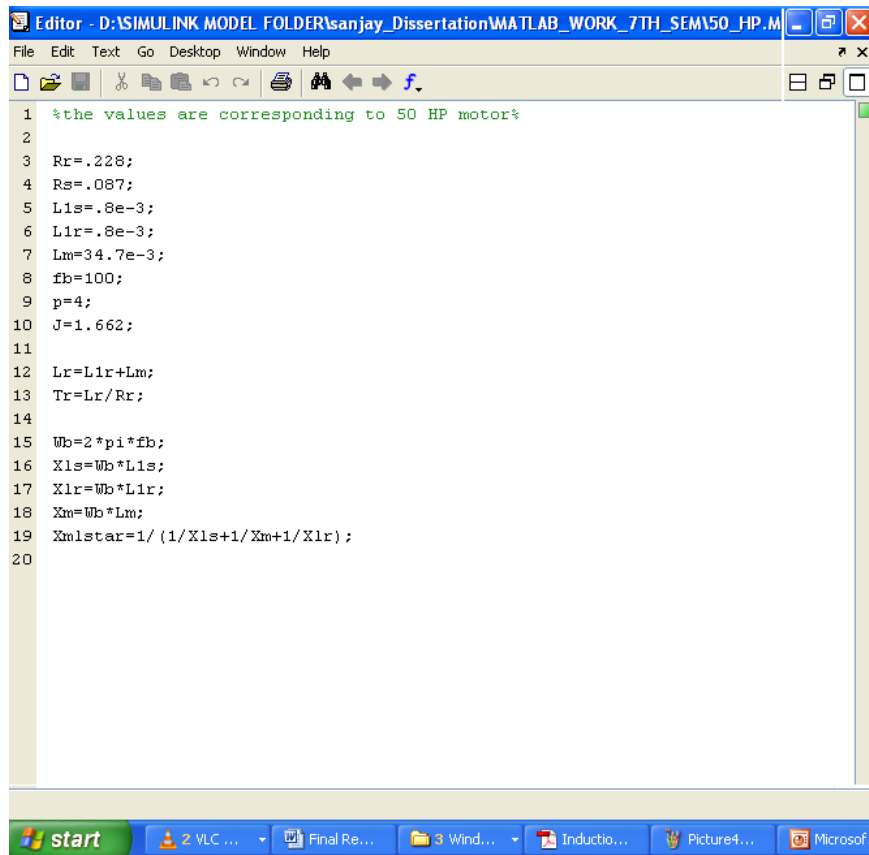

Figure 41.  $\omega_r$  matlab simulink block.  
 block sub-system.

Figure 42.  $\omega_r$  matlab simulink  
 block sub-system.

- Induction Machine Parameters values corresponding to 50 HP motor



```
Editor - D:\SIMULINK MODEL FOLDER\sanjay_Dissertation\MATLAB_WORK_7TH_SEM\50_HP.M
File Edit Text Go Desktop Window Help
1 %the values are corresponding to 50 HP motor%
2
3 Rr=.228;
4 Rs=.087;
5 Lls=.8e-3;
6 Llr=.8e-3;
7 Lm=34.7e-3;
8 fb=100;
9 p=4;
10 J=1.662;
11
12 Lr=Llr+Lm;
13 Tr=Lr/Rr;
14
15 Wb=2*pi*fb;
16 Xls=Wb*Lls;
17 Xlr=Wb*Llr;
18 Xm=Wb*Lm;
19 Xmstar=1/(1/Xls+1/Xm+1/Xlr);
20
```

*Figure 43. Parameters of induction machine.*

**[F] INDUCTION MACHINE D-Q SIMULATION MODEL**

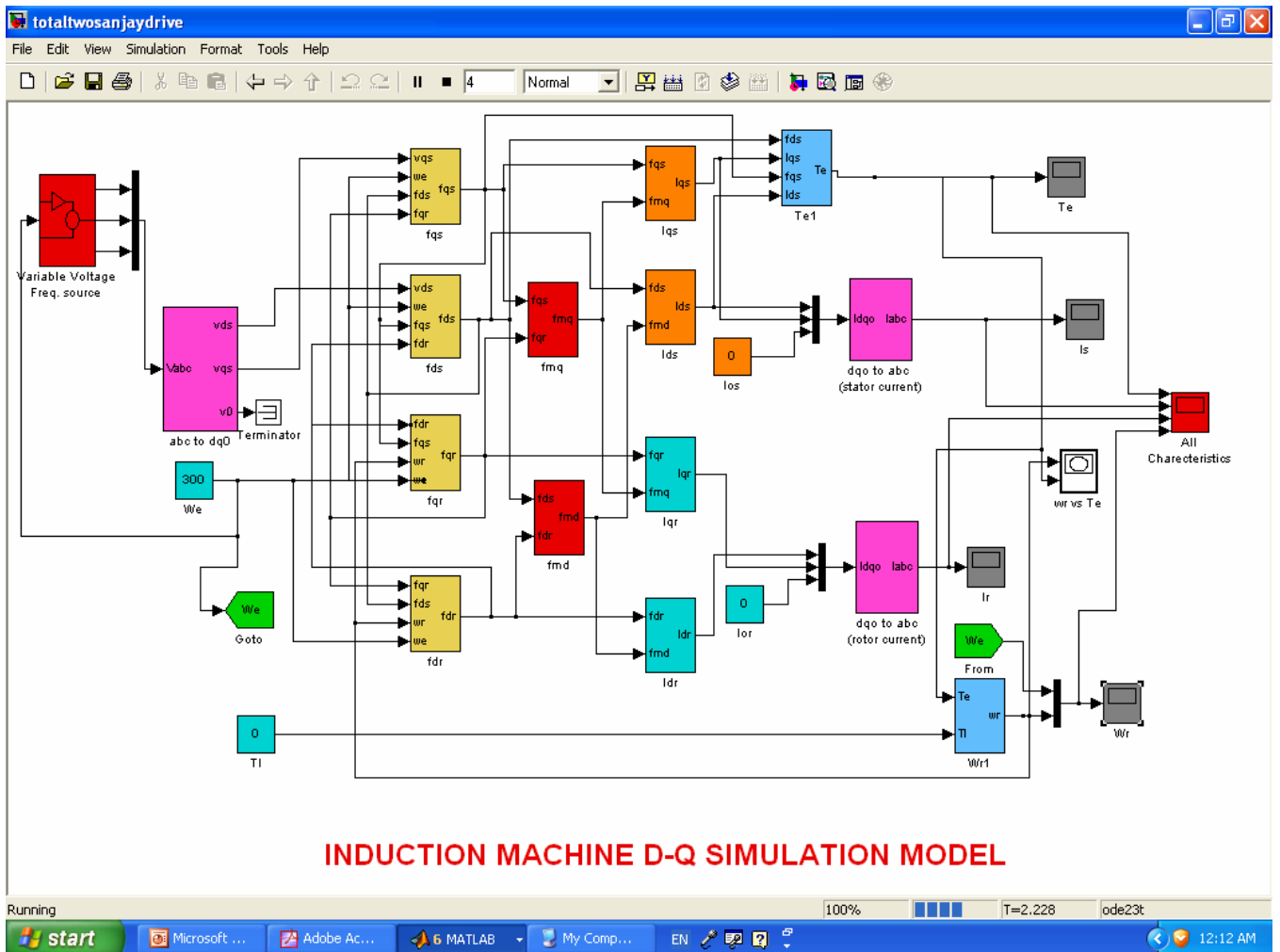
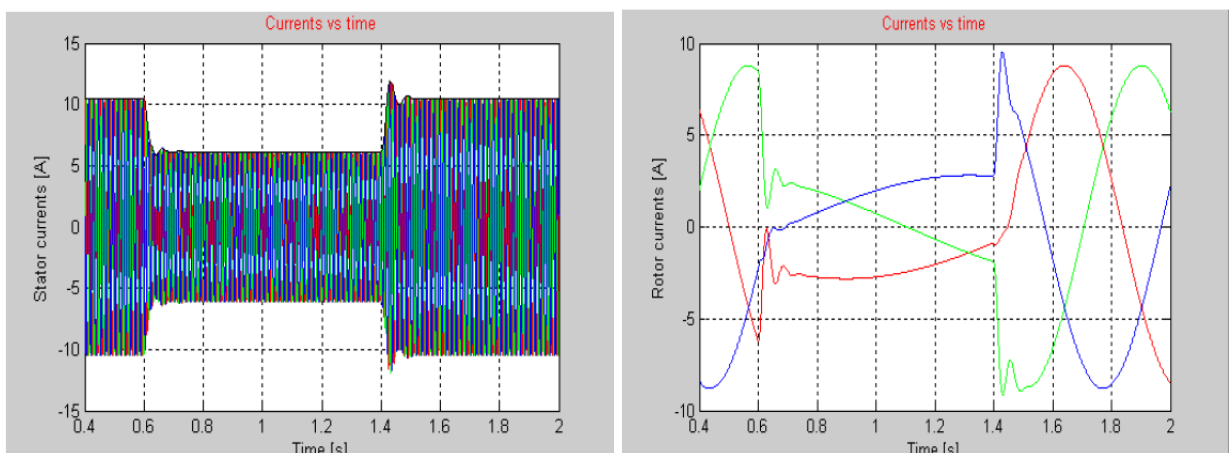
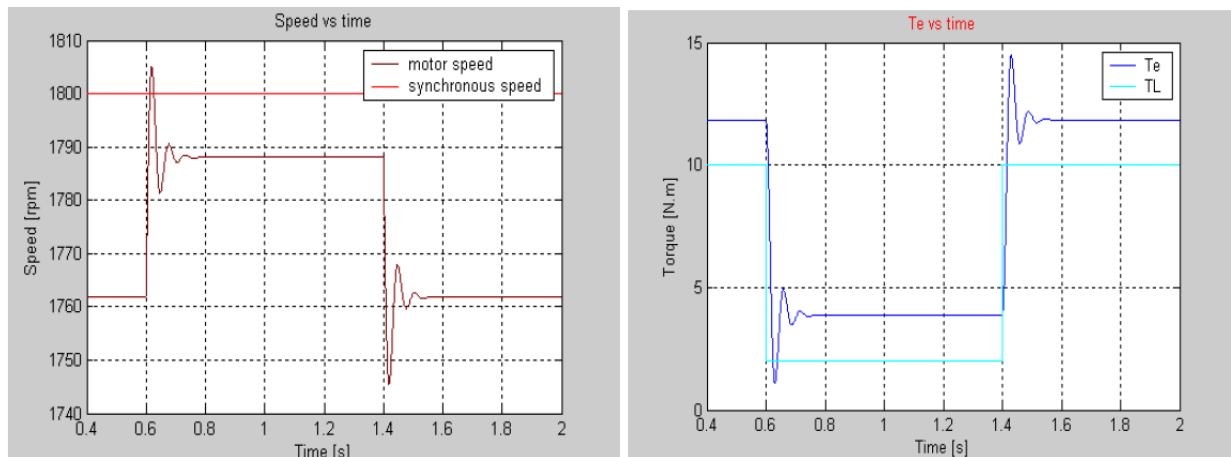

Figure 44. Induction machine D-Q simulink model.

[G] Graphical Displays:





**Figure 45. Performance wave form of induction motor**

## VI. CONCLUSIONS

In this paper, implementation of a modular simulink model for induction machine simulation has been introduced. Unlike most other induction machine model implementations, with this model, the user has access to all the internal variables for getting an insight into the machine operation. Any machine control algorithm can be simulated in the Simulink environment with this model without actually using estimators. If need be, when the estimators are developed, they can be verified using the signals in the machine model. The ease of implementing controls with this model is also demonstrated with several examples.

## REFERENCES

- [1] H. Le-Huy, "Modeling and simulation of electrical drives using Matlab/Simulink and Power System Blockset," *The 27th Annual Conference of the IEEE Industrial Electronics Society (IECON'01)*, Denver/Colorado, pp. 1603-1611.
- [2] Burak Ozpineci & Leon M. Tolbert., Simulink Implementation of Induction Machine Model– A Modular Approach, 0- 7803-7817-2/03 ©2003 IEEE
- [3] M. L. de Aguiar, M. M. Cad, "The concept of complex transfer functions applied to the modeling of induction motors," *Power engineering Society Winter Meeting*, 2000, pp. 387 -391.
- [4] K. L . SHI, T . F. CHAN, Y. K. WONG and S. L HO, Modeling and simulation of the three phase induction motor using simulink. ,Department of Electrical Engineering, Hong Kong Polytechnic University, Hong Kong
- [5] Krause, P. C., 'Simulation of symmetrical induction machinery', IEEE Trans. Power Apparatus Systems, Vol. PAS-84, No. 11, pp. 1038–1053 (1965).